



Indian Summer Show

24/09 – 25/09, 2021

Rawhide Ranch – Dikberd 29 – 2200 Herentals

BELGIAN
QUARTER
HORSE
ASSOCIATION

Showmanship at Halter

PRAB: W&J <13, W&J >13, Beginners, Nov Youth, Nov Amateur

AQHA: L1 Youth, L1 Amateur

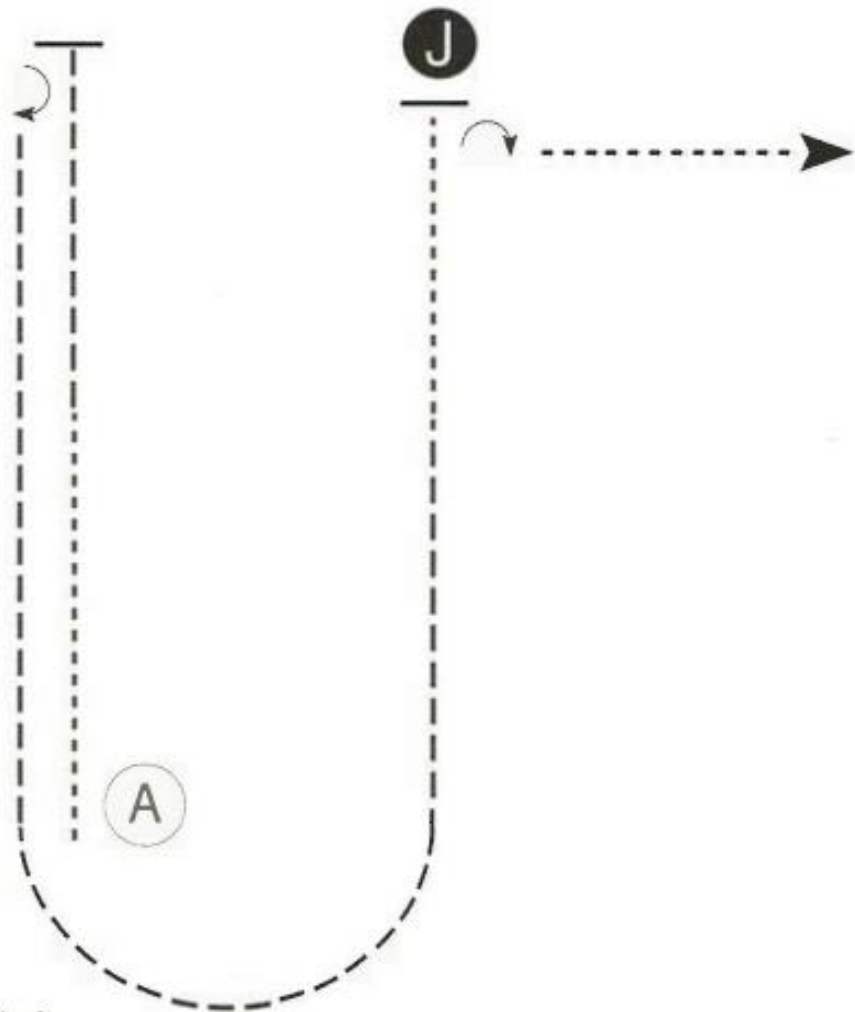

Be ready at A.

1. Walk halfway from A to judge.
 2. Trot until even with judge.
 3. Stop and perform a 180 degree turn.
 4. Trot to and around A and halfway to judge.
 5. Walk to judge.
 6. Stop and set up for inspection.
 7. When dismissed, perform a 90 degree turn.
 8. Walk straight away from judge.
- Follow the instructions of your ring steward.

Walk	-----
Trot	- - - - -
Back	←
Marker	Ⓚ
Judge	Ⓝ



Indian Summer Show

24/09 – 25/09, 2021

Rawhide Ranch – Dikberd 29 – 2200 Herentals

BELGIAN
QUARTER
HORSE
ASSOCIATION

Showmanship at Halter

PRAB: Youth, Amateur, Open

AQHA: Youth, Amateur

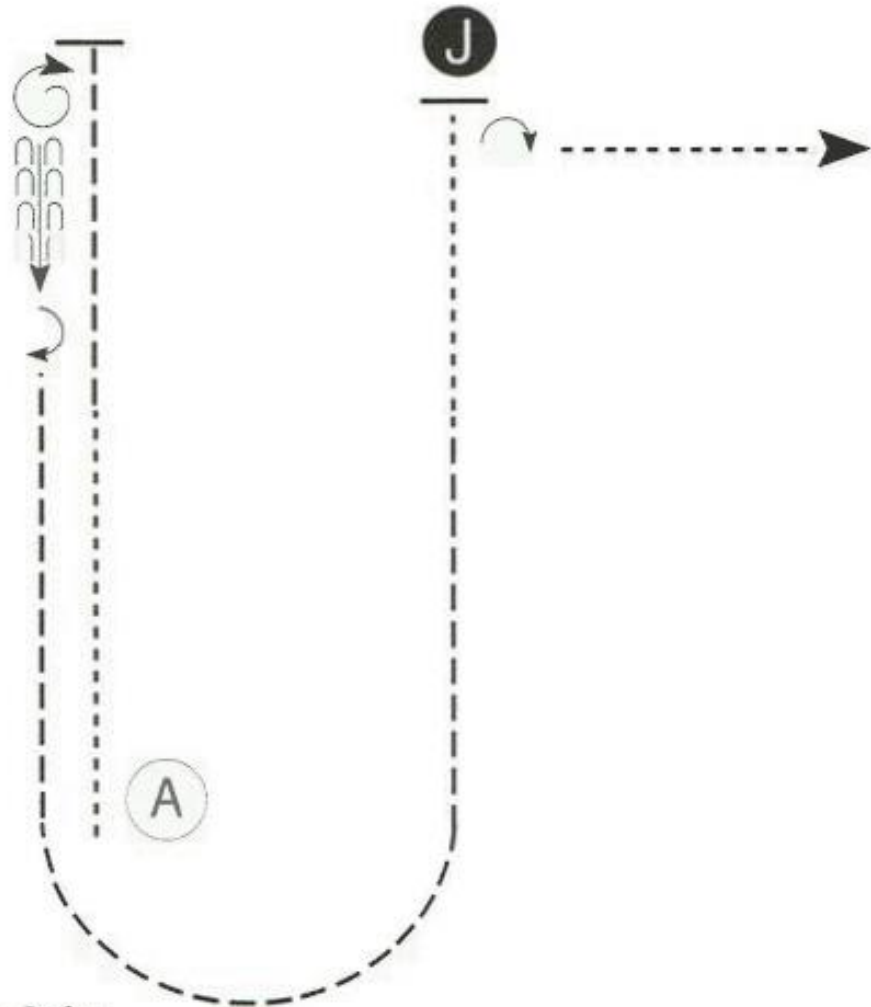

Be ready at A.

1. Walk half way from A to Judge.
 2. Trot until even with judge.
 3. Stop and perform a 360 degree turn.
 4. Back approximately two horse lengths.
 5. Perform a 180 degree turn.
 6. Trot to and around A and halfway to judge.
 7. Walk to judge.
 8. Stop and set up for inspection.
 9. When dismissed, perform a 90 degree turn.
 10. Walk straight away from judge.
- Follow the instructions of your ring steward.

Walk	-----
Trot	- - - - -
Back	←
Marker	ⓑ
Judge	ⓐ



Indian Summer Show

24/09 – 25/09, 2021

Rawhide Ranch – Dikberd 29 – 2200 Herentals

BELGIAN
QUARTER
HORSE
ASSOCIATION

Western Horsemanship

PRAB: Beginners, Nov Youth, Nov Amateur

AQHA: L1 Youth, L1 Amateur

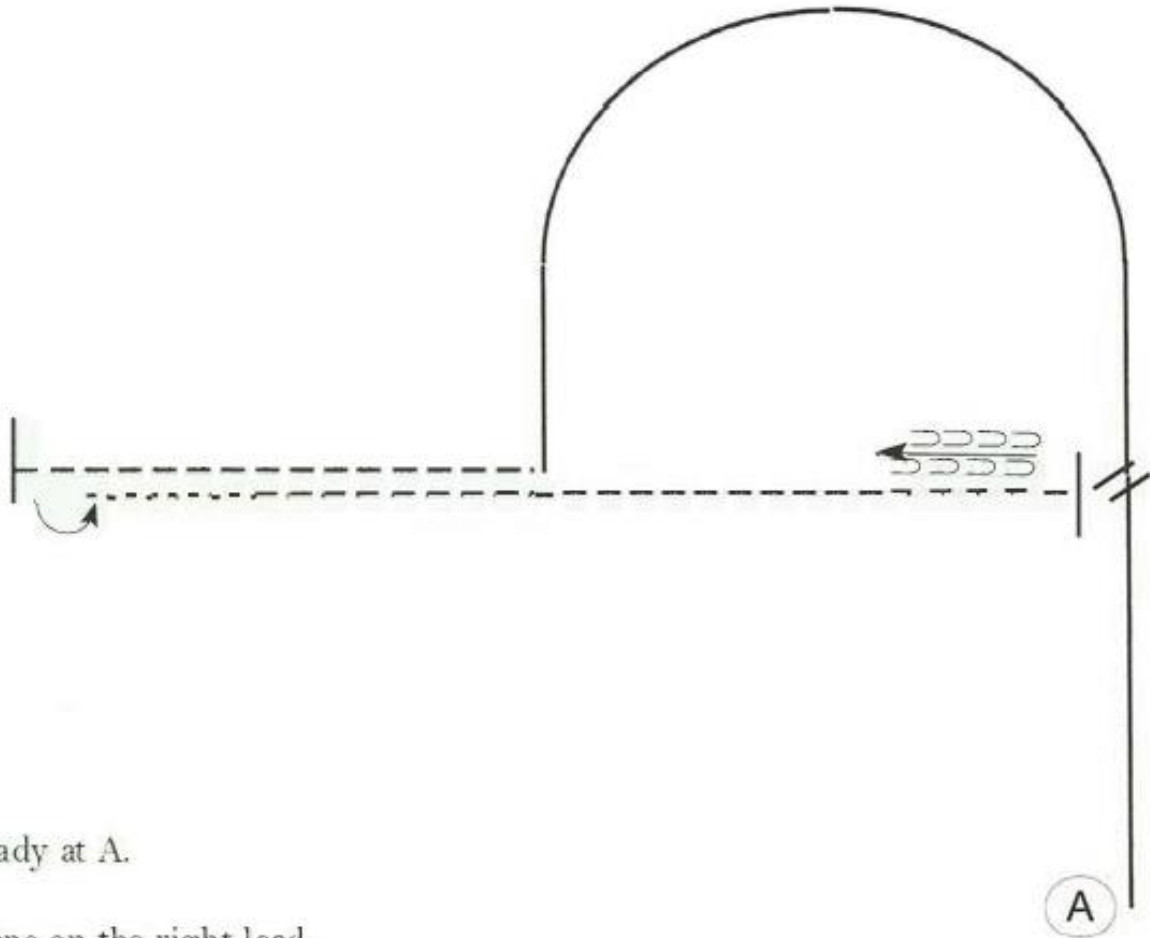

Be ready at A.

1. Lope on the right lead.
2. Perform a simple lead change in the middle of your line.
3. Lope in an arc to the middle of your pattern.
4. Break to a jog and jog a corner to the right.
5. Perform 1/2 turn to the left.
6. Walk halfway to middle.
7. Jog until even with A as shown.
8. Stop and back.

Walk	-----
Jog	-----
Extended Jog	-----
Lope	-----
Lead Change	
Back	
Marker	(A)



Indian Summer Show

24/09 – 25/09, 2021

Rawhide Ranch – Dikberd 29 – 2200 Herentals

BELGIAN
QUARTER
HQRSE
ASSOCIATION

Western Horsemanship

PRAB: Youth, Amateur

AQHA: Youth, Amateur

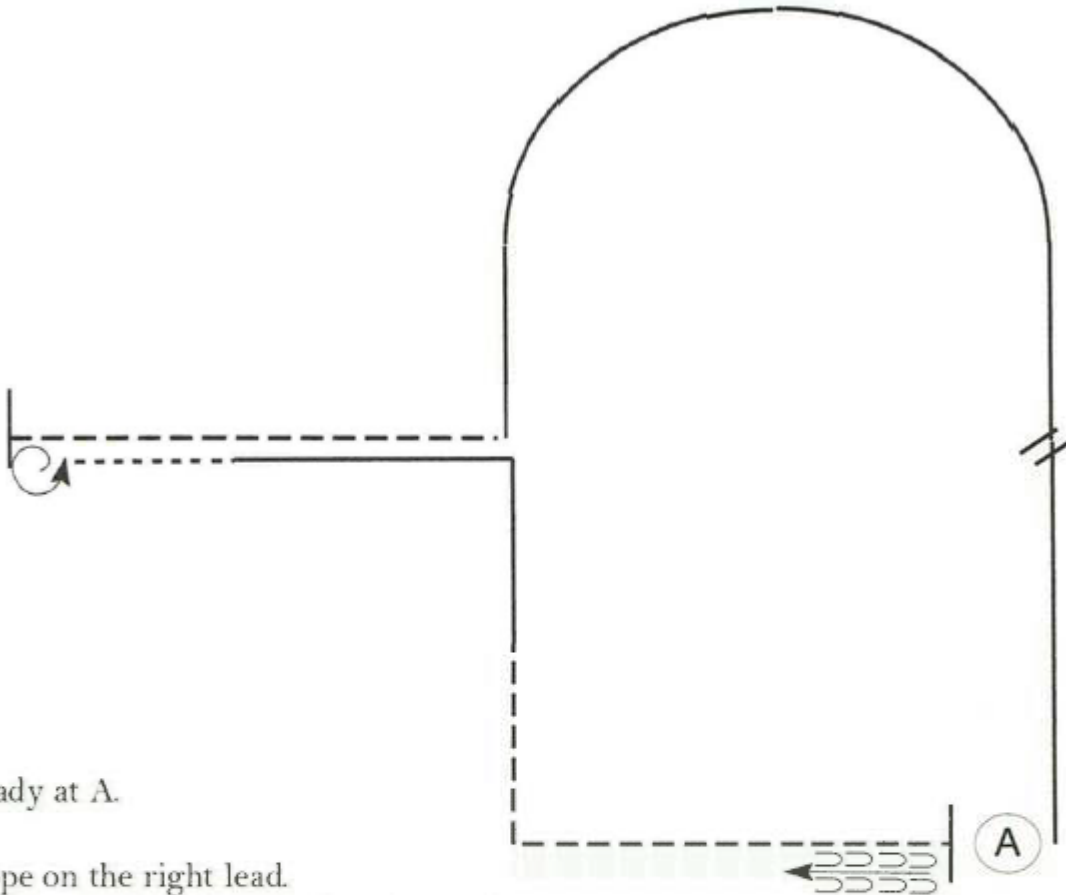

Be ready at A.

1. Lope on the right lead.
2. Change leads in the middle of your line.
3. Lope in an arc to the middle of your pattern.
4. Break to a jog and jog a corner to the right.
5. Perform 1 1/2 turns to the left.
6. Walk halfway to middle.
7. Lope on the right lead until you are halfway to A as shown.
8. Jog to A. Stop and back.

Walk	-----
Jog	-----
Extended Jog	-----
Lope	=====
Lead Change	⚡
Back	←=====
Marker	Ⓚ



Indian Summer Show

24/09 – 25/09, 2021

Rawhide Ranch – Dikberd 29 – 2200 Herentals

BELGIAN
QUARTER
HORSE
ASSOCIATION

Western Horsemanship

PRAB: W&J <13, W&J >13

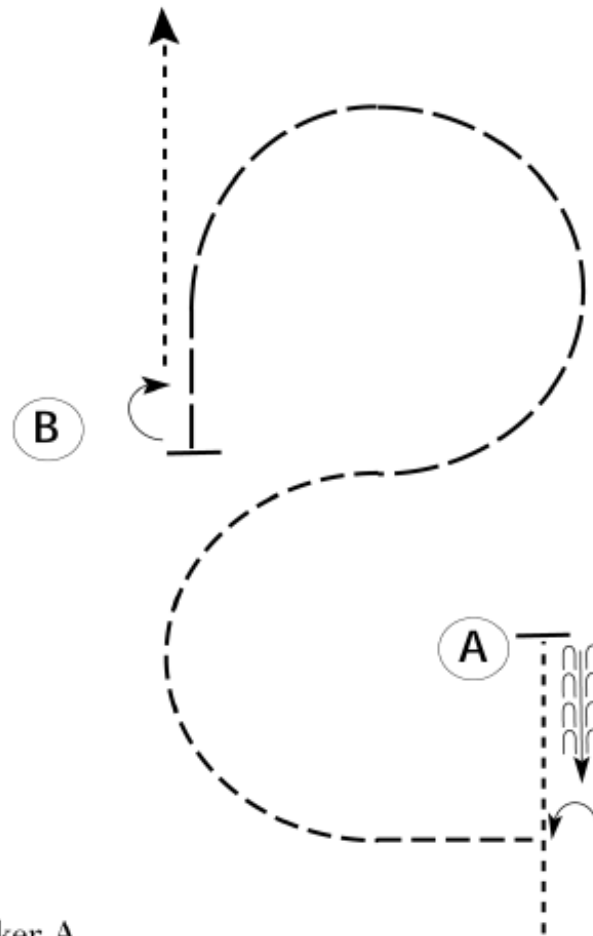

Be ready before marker A.

1. Walk to A.
2. Stop and back approximately one horse length.
3. Execute a 1/4 turn to the left and jog a half circle.
4. Extend the jog to B.
5. Stop at B and execute a 1/2 turn to the right.
6. Walk to exit.

Follow the instructions of your ring steward.

Walk	-----
Jog	-----
Extended Jog	-----
Lope	—————
Leg Yield	
Lead Change	—/—
Back	← 3 3 3 3
Marker	(B)



Indian Summer Show

24/09 – 25/09, 2021

Rawhide Ranch – Dikberd 29 – 2200 Herentals

BELGIAN
QUARTER
HORSE
ASSOCIATION

Hunt Seat Equitation

AQHA: L1 Youth, L1 Amateur

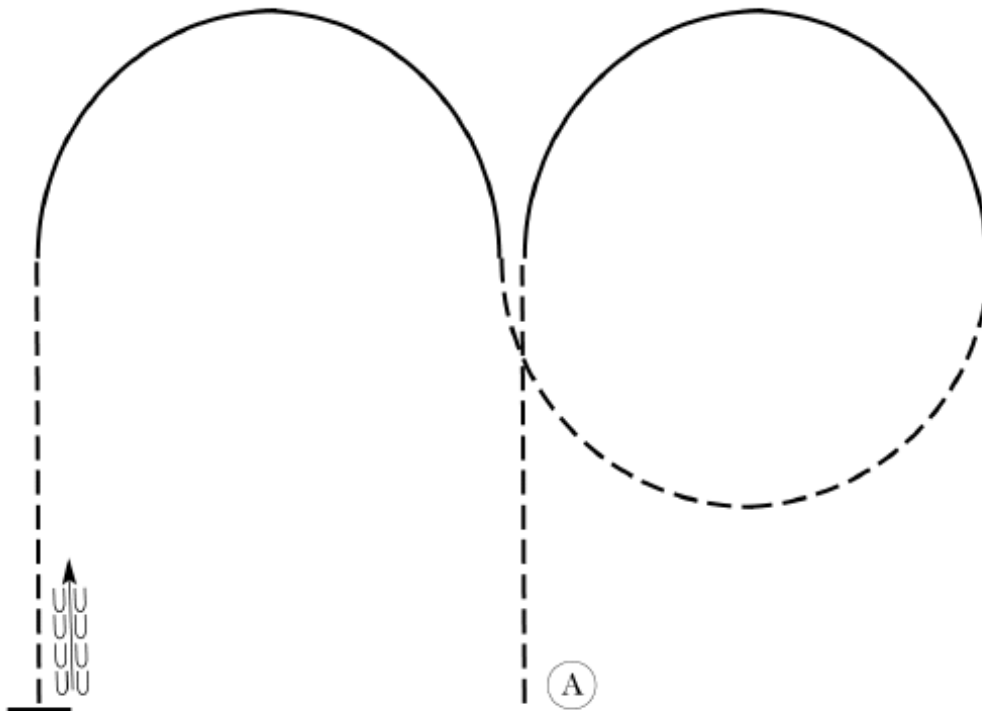

Be ready at A.

1. Trot on the right diagonal.
2. Counter canter 1/2 circle.
3. Break to a posting trot on the left diagonal.
4. Canter 1/2 circle on the left lead.
5. Sitting trot to the finish.
6. Stop and back one horse length.

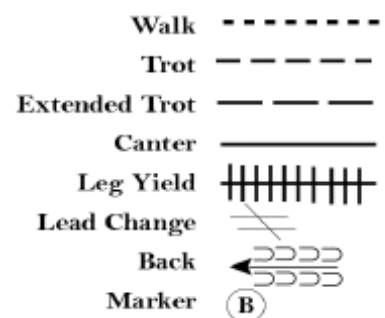



Indian Summer Show

24/09 – 25/09, 2021

Rawhide Ranch – Dikberd 29 – 2200 Herentals

BELGIAN
QUARTER
HORSE
ASSOCIATION

Hunt Seat Equitation

AQHA: Youth, Amateur

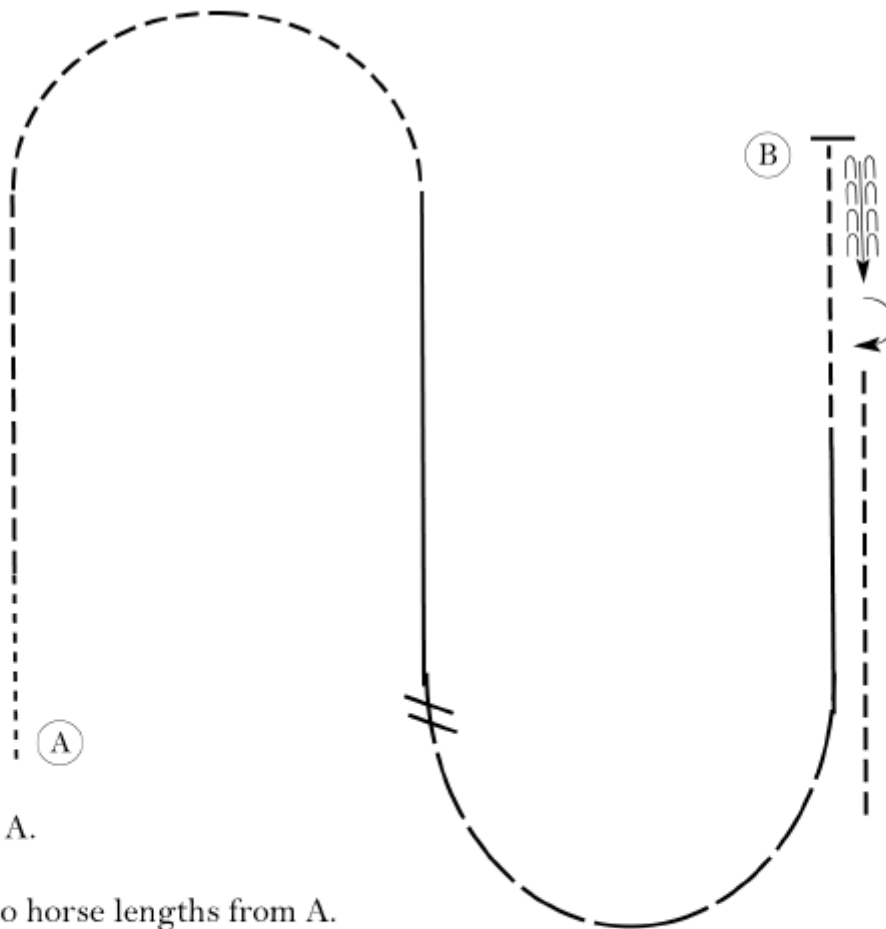

Be ready at A.

1. Walk two horse lengths from A.
2. Trot on the right diagonal until even with B.
3. Change diagonals and trot a half circle.
4. Canter on the right lead until even with A.
5. Change leads and hand gallop a half circle.
6. Slow to a canter and canter halfway to B.
7. Sitting trot to B.
8. Stop when even with B and back approximately one horse length.
9. Turn right 180 degrees on the forehand.
10. Exit at a sitting trot.

Walk	-----
Trot	- - - - -
Extended Trot	- - - - -
Canter	—————
Leg Yield	
Lead Change	///
Back	←←←←← →→→→→
Marker	(B)
Sidepass	←←←←←
Hand Gallop	—————



Indian Summer Show

24/09 – 25/09, 2021

Rawhide Ranch – Dikberd 29 – 2200 Herentals

BELGIAN
QUARTER
HORSE
ASSOCIATION

Ranch Riding **RANCH RIDING – PATTERN 2**

PRAB: Beginners

AQHA: L1 Youth, L1 Amateur, L1 Open

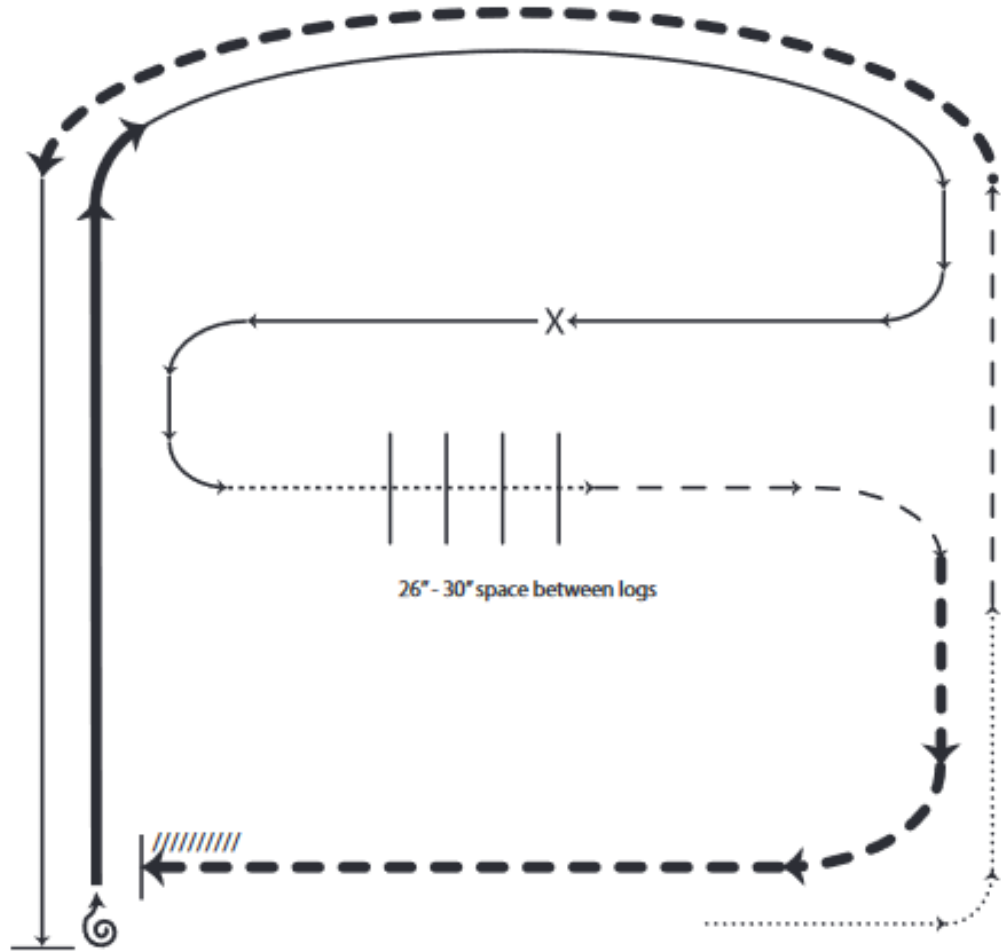

1. Walk
2. Trot
3. Extended trot
4. Left lead lope
5. Stop, 1/2 turn right
6. Extended lope
7. Collect to working lope-right lead
8. Change leads (simple or flying)
9. Walk
10. Walk over logs
11. Trot
12. Extended trot
13. Stop and back

Note: The drawn description of this pattern is only intended for the general depiction of the pattern. Exhibitors should utilize the arena space to best exhibit their horses.

- X Lead Change
- • Walk
- - Trot
- - - Ext Trot
- — — Lope
- — — — Ext Lope
- //// //// Back



Indian Summer Show

24/09 – 25/09, 2021

Rawhide Ranch – Dikberd 29 – 2200 Herentals

BELGIAN
QUARTER
HORSE
ASSOCIATION

Ranch Riding

PRAB: Open **RANCH RIDING – PATTERN 4**

AQHA: Youth, Amateur, Open

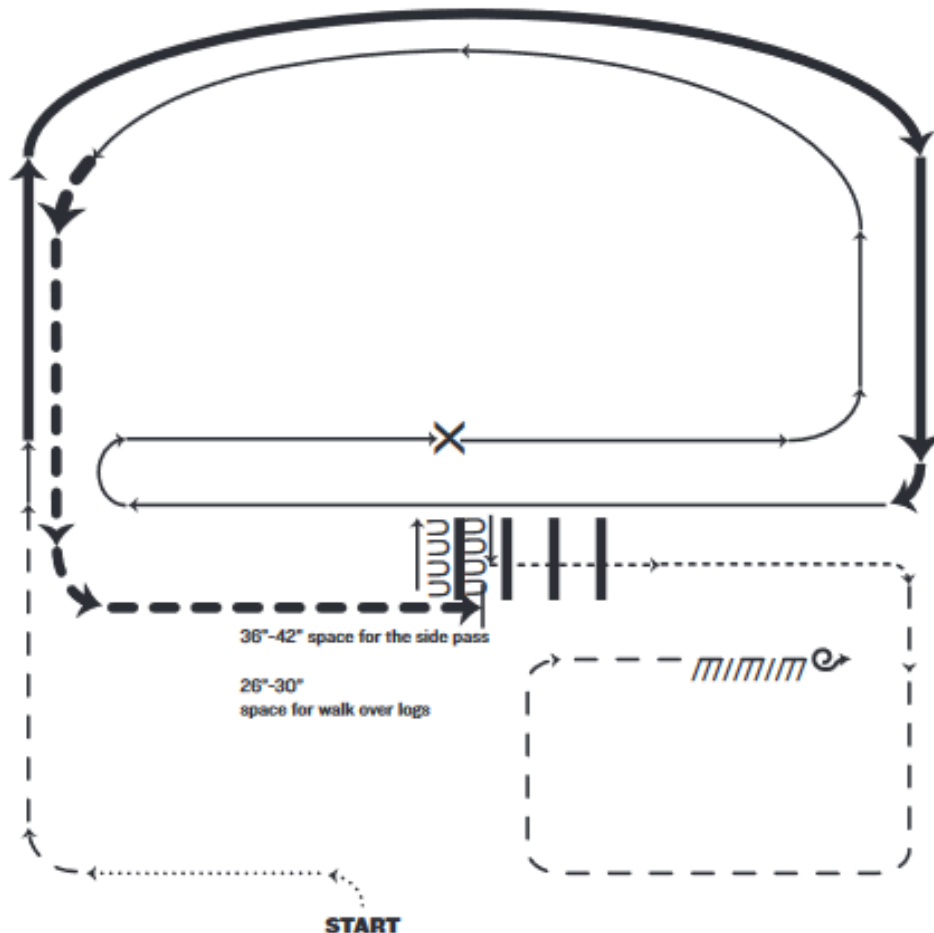

1. Walk
2. Trot
3. Extended lope right lead
4. Lope right lead
5. Change leads (simple or flying)
6. Lope left lead
7. Extended trot
8. Stop, side pass left, side pass right, 1/2 way
9. Walk over logs
10. Walk
11. Trot square
12. Stop, 360° turn left, back

- X Lead Change
- • Walk
- - Trot
- — Ext Trot
- — Lope
- — Ext Lope
- //// Back

Note: The drawn description of this pattern is only intended for the general depiction of the pattern. Exhibitors should utilize the arena space to best exhibit their horses.



Indian Summer Show

24/09 – 25/09, 2021

Rawhide Ranch – Dikberd 29 – 2200 Herentals

BELGIAN
QUARTER
HORSE
ASSOCIATION

Western Riding

PRAB: Open Green Horse

AQHA: L1 Youth, L1 Amateur, L1 Open

LEVEL I WESTERN RIDING PATTERN 4

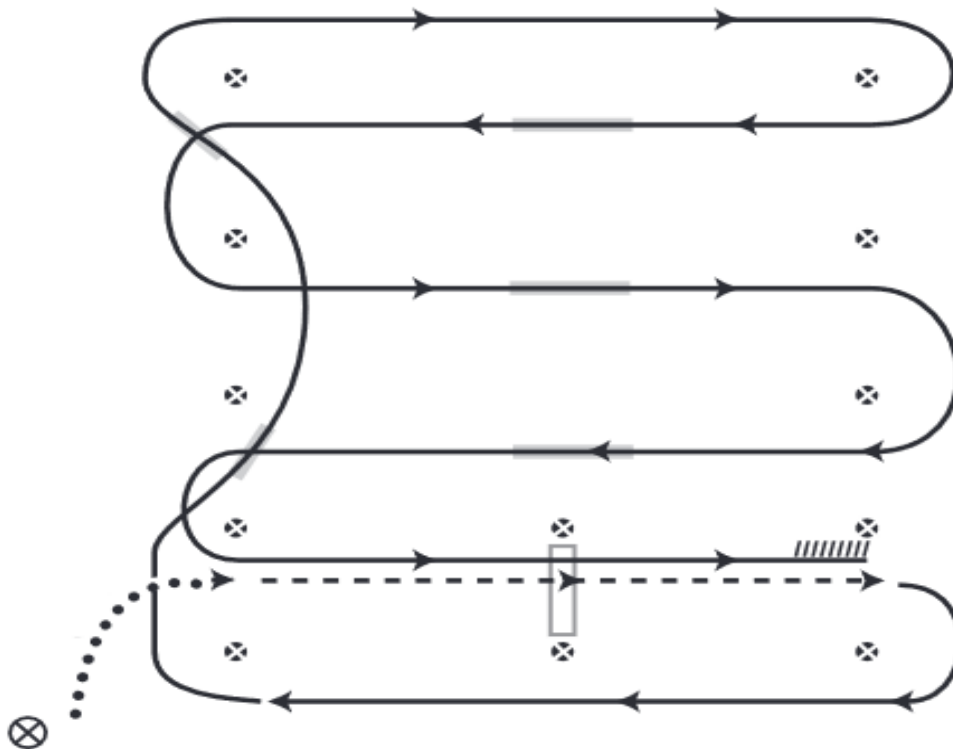

1. Walk at least 15 feet from start cone to the first marker, as drawn, transition to jog, jog over log.
2. Transition to right lead & lope around end
3. First line change
4. Second line change, lope around end of arena
5. First crossing change
6. Second crossing change
7. Third crossing change
8. Lope over log
9. Lope, stop & back



Indian Summer Show

24/09 – 25/09, 2021

Rawhide Ranch – Dikberd 29 – 2200 Herentals

BELGIAN
QUARTER
HORSE
ASSOCIATION

Western Riding

AQHA: Youth, Amateur, Open

WESTERN RIDING PATTERN 4

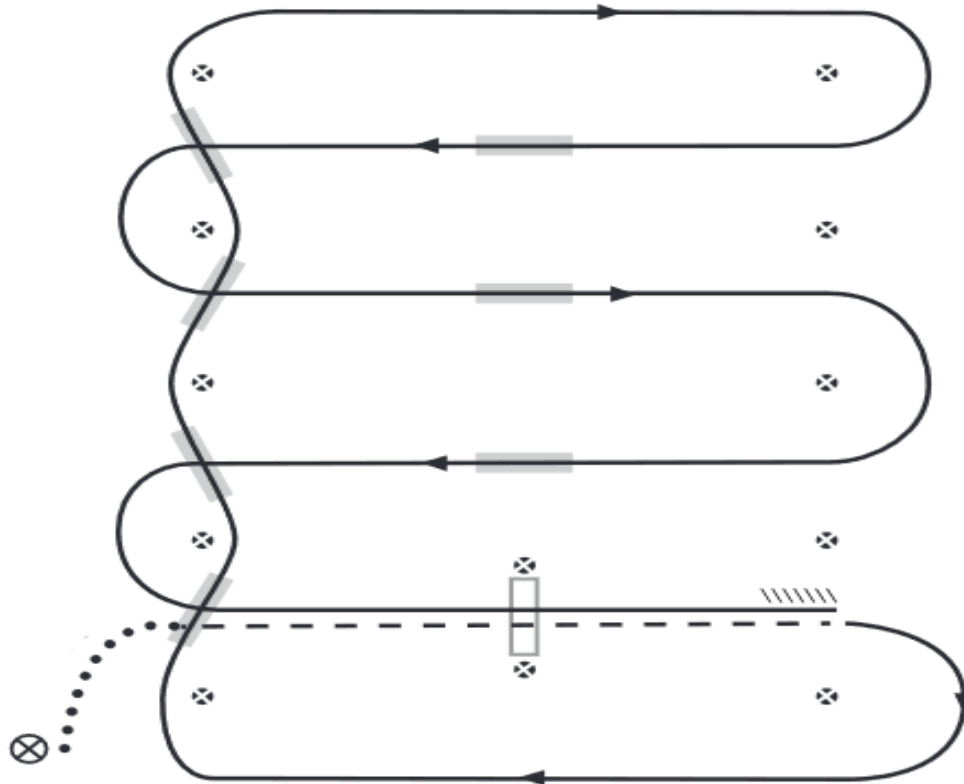

- I. Walk at least 15 feet from start cone to the first marker, as drawn, transition to jog, jog over log.
2. Transition to the lope, on the right lead
3. First line change
4. Second line change
5. Third line change
6. Fourth line change
7. First crossing change
8. Second crossing change
9. Third crossing change
10. Lope over log
- II. Lope, stop & back



Indian Summer Show

24/09 – 25/09, 2021

Rawhide Ranch – Dikberd 29 – 2200 Herentals

BELGIAN
QUARTER
HORSE
ASSOCIATION

Reining

PRAB: Beginners

AQHA: L1 Youth, L1 Amateur

REINING PATTERN B

Approved only for Level I Youth & Amateur, Youth I3 & Under

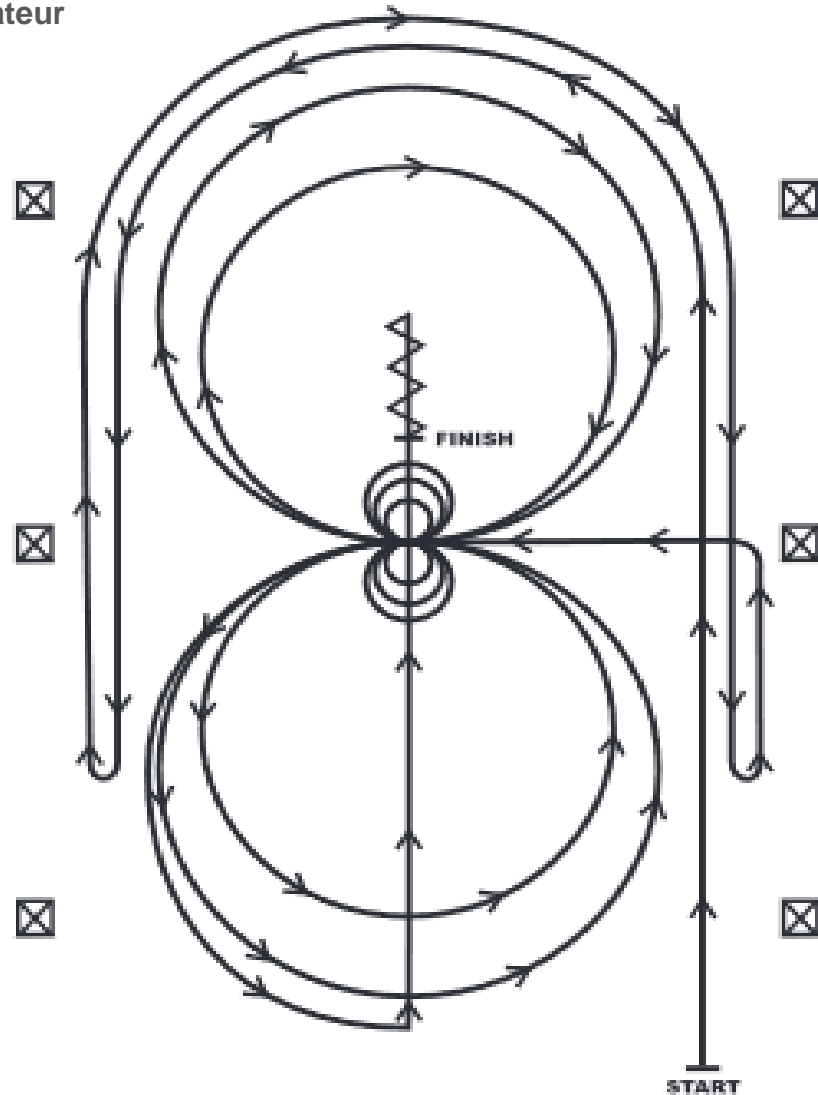

1. Beginning, lope straight up the right side of the arena, circle the top of the arena run straight down the opposite or left side of the arena past the center mark and do a right rollback—no hesitation.
2. Continue straight up the left side of the arena circle back around the top of the arena run straight down the right side of the arena past the center marker and do a left rollback—no hesitation.
3. Continue up the right side of the arena to the center marker, at the center marker the horse should be on the left lead and complete two circles to the left, one large fast and one small slow. Stop at center
4. Complete three spins to the left. Hesitate.
5. Complete two circles to the right, one large fast and one small slow. Stop at center.
6. Complete three spins to the right. Hesitate.
7. Begin a large circle to the left, do not close the circle. Continue up the center of the arena past the center marker and do a sliding stop.
8. Back up at least ten feet. Hesitate to demonstrate completion of the pattern.



Indian Summer Show

24/09 – 25/09, 2021

Rawhide Ranch – Dikberd 29 – 2200 Herentals

BELGIAN
QUARTER
HORSE
ASSOCIATION

REINING PATTERN 11

Reining

PRAB: Open

AQHA: Youth, Amateur, Open

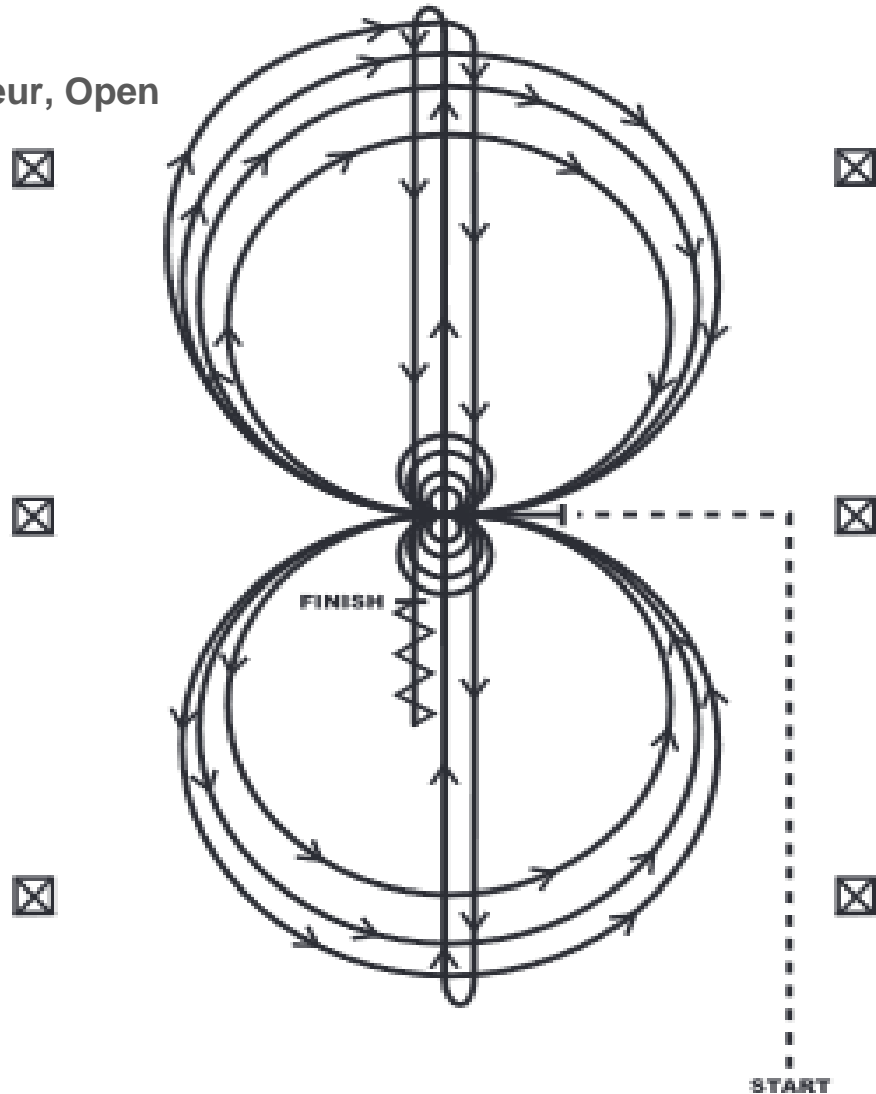

Horses must jog to the center of the arena. Horses must walk or stop prior to starting the pattern. Beginning at the center of the arena facing the left wall or fence.

1. Complete four spins to the left. Hesitate.
2. Complete four spins to the right. Hesitate.
3. Beginning on the right lead complete three circles to the right; the first circle small and slow; the next two circles large and fast. Change leads at the center of the arena.
4. Complete three circles to the left; the first circle small and slow; the next two circles large and fast. Change leads at the center of the arena.
5. Begin a large circle to the right, but do not close this circle. Run down the center of the arena past the end marker and do a right rollback—no hesitation.
6. Run up the middle to the opposite end of the arena past the end marker and do a left rollback—no hesitation.
7. Run past the center marker and do a sliding stop. Back up to the center of the arena or at least ten feet (three meters). Hesitate to demonstrate completion of the pattern.



Indian Summer Show

24/09 – 25/09, 2021

Rawhide Ranch – Dikberd 29 – 2200 Herentals

BELGIAN
QUARTER
HORSE
ASSOCIATION

Trail

PRAB: W&J <13, W&J >13, In Hand Trail Open

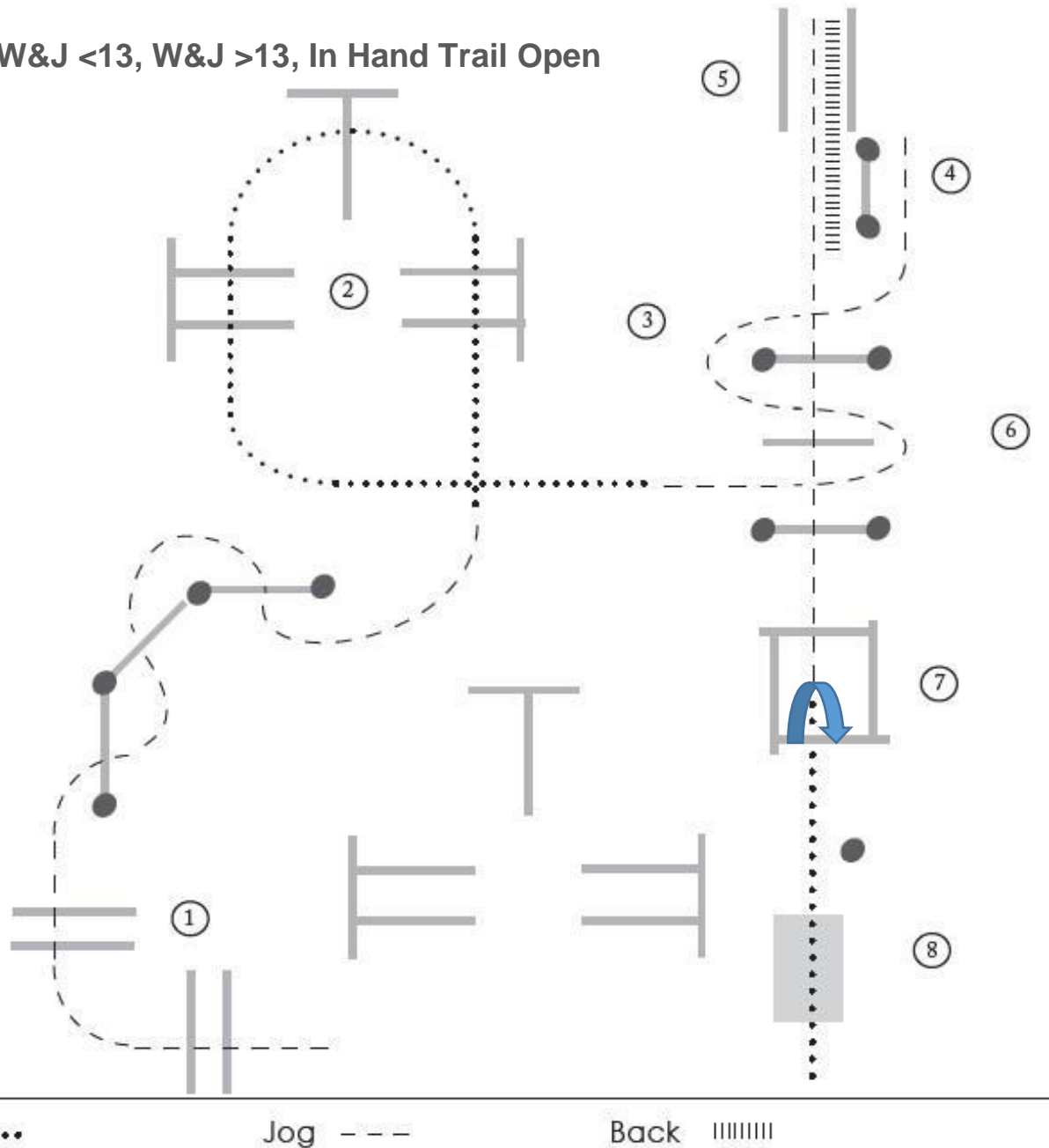

1. Jog over poles
2. Walk over poles
3. Jog Serpentine
4. Work gate, left hand
5. Back into chute
6. Jog over poles
7. Jog in Box, Stop in box, 360° Turn Right
8. Walk over bridge to finish



Indian Summer Show

24/09 – 25/09, 2021

Rawhide Ranch – Dikberd 29 – 2200 Herentals

BELGIAN
QUARTER
HORSE
ASSOCIATION

Trail

PRAB: Beginners, Green Horse Open, Nov Youth, Nov Amateur
AQHA: L1 Youth, L1 Amateur, L1 Open

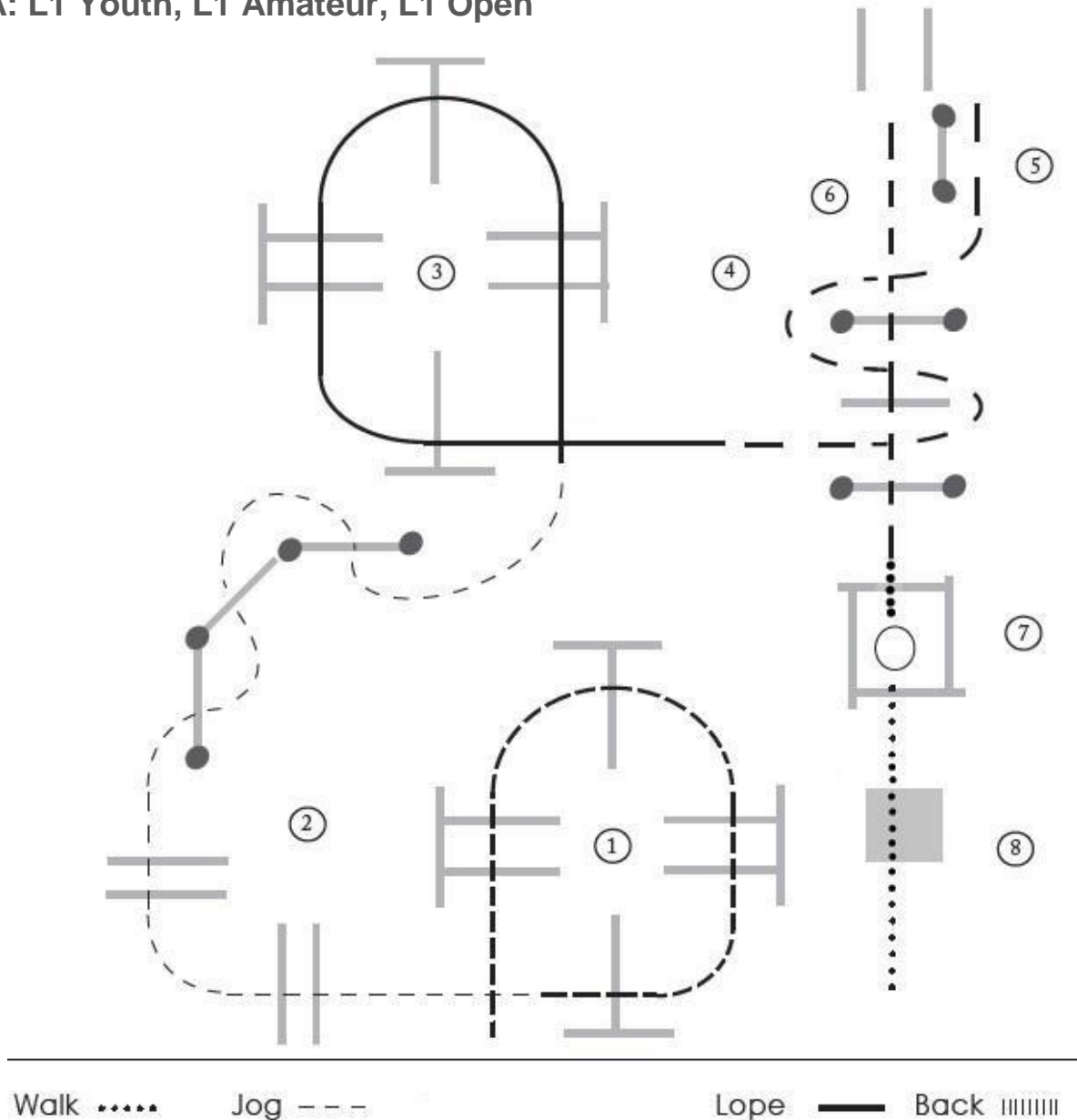

1. Jog over poles.
2. Jog over poles.
3. Lope left lead over poles.
4. Jog serpentine, Stop
5. Work gate, left hand.
6. Jog over poles
7. Walk in, one turn (L or R) and walk out box
8. Walk over bridge to finish



Indian Summer Show

24/09 – 25/09, 2021

Rawhide Ranch – Dikberd 29 – 2200 Herentals

BELGIAN
QUARTER
HORSE
ASSOCIATION

Trail

PRAB: Youth, Amateur
AQHA: Youth, Amateur

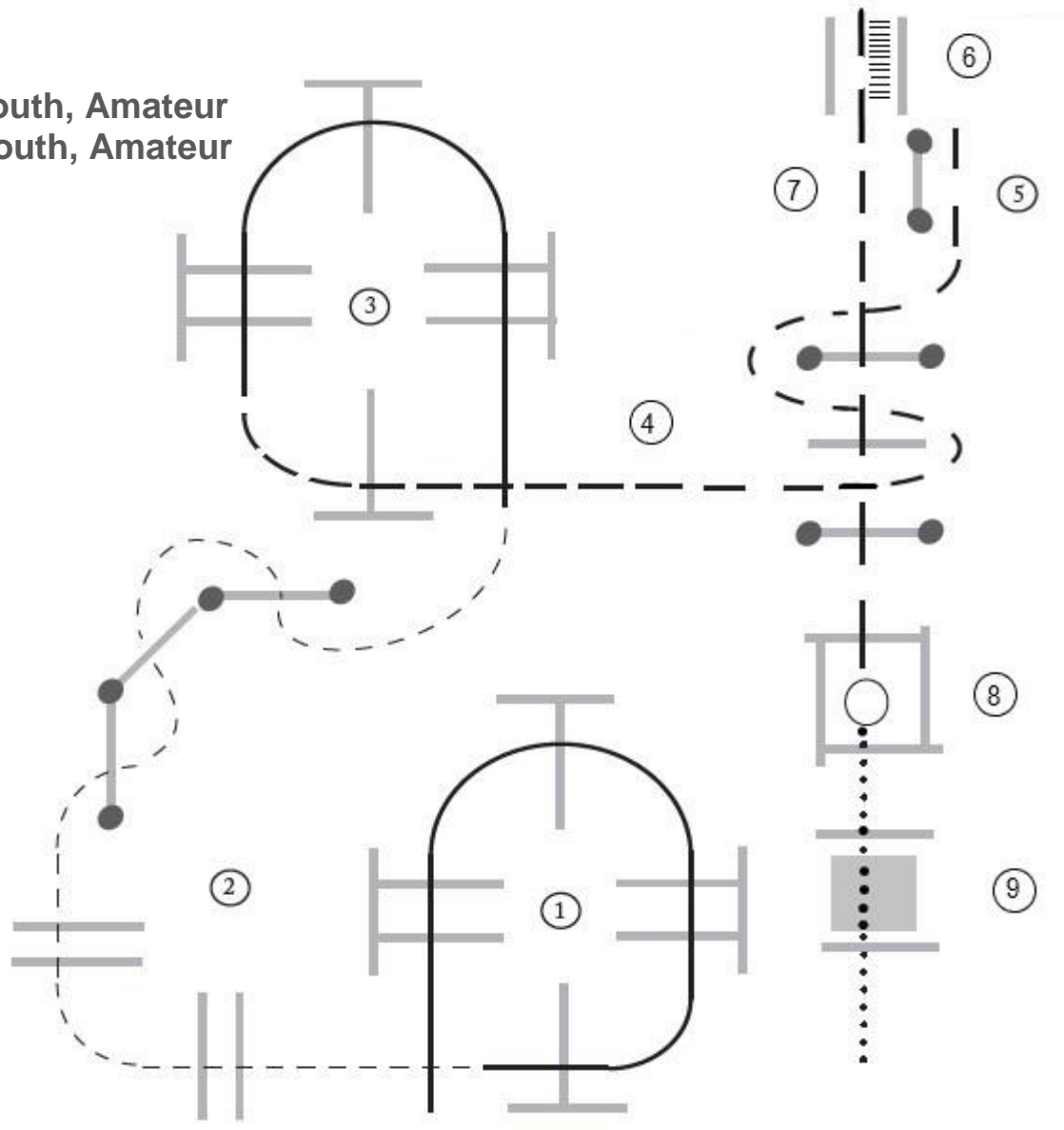

Walk Jog - - - Extended jog - - - Lope ——— Back |||||

1. Lope right lead over poles.
2. Jog over poles.
3. Lope left lead over poles.
4. Jog over pole, jog serpentine, Stop
5. Work gate, left hand.
6. Back into chute.
7. Extended Jog over poles
8. Extended Jog in, one turn (L or R) and walk out box
9. Walk over bridge to finish



Indian Summer Show

24/09 – 25/09, 2021

Rawhide Ranch – Dikberd 29 – 2200 Herentals

BELGIAN
QUARTER
HORSE
ASSOCIATION

Trail

PRAB: Open
AQHA: Open

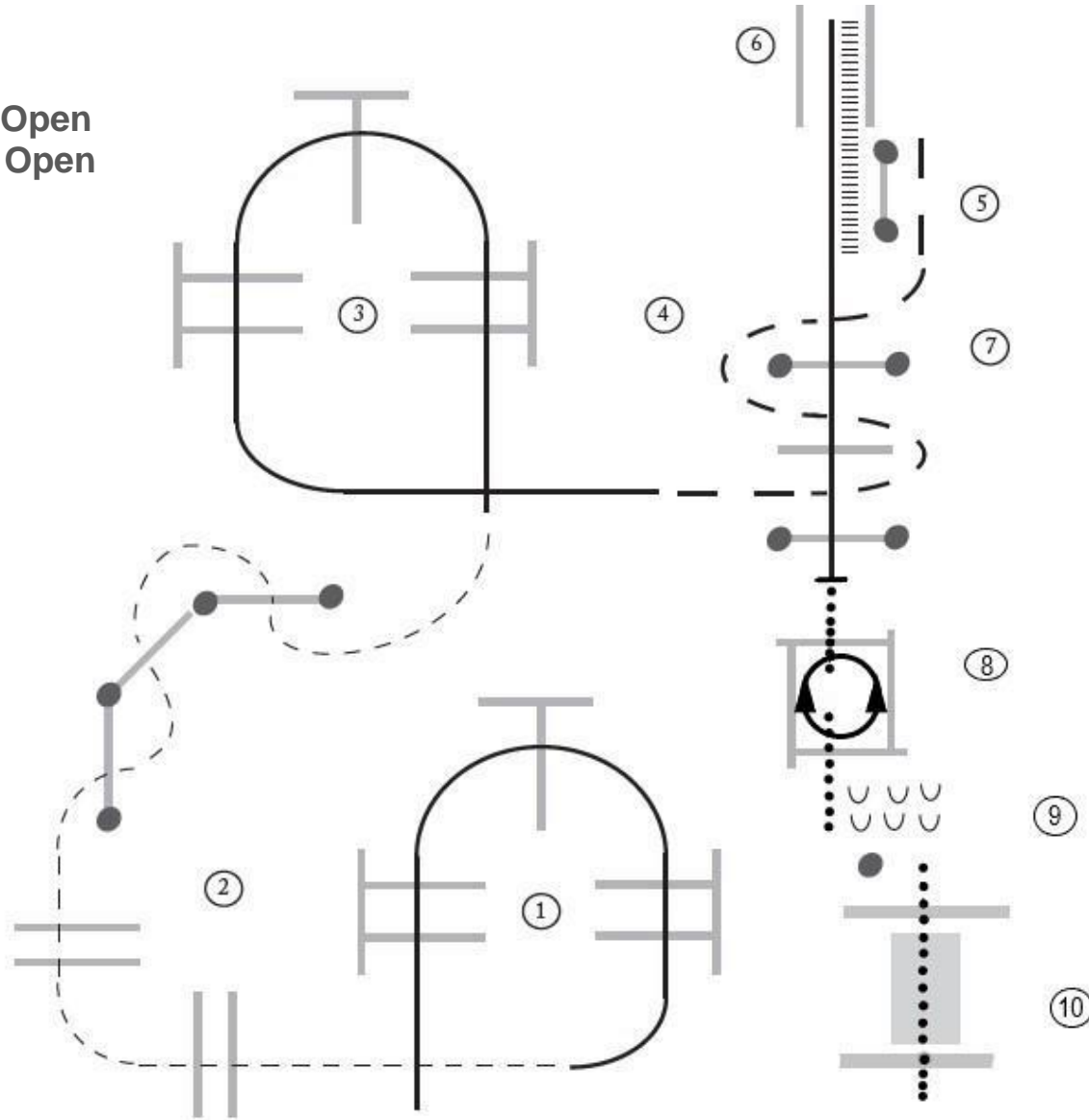

Walk Jog - - - Extended jog - - - Lope — Back ||||| Sidepass ∩ ∩

1. Lope right lead over poles.
2. Jog over poles.
3. Lope left lead over poles.
4. Extended jog serpentine.
5. Work gate, left hand.
6. Back into chute.
7. Lope, either lead, over poles, Stop
8. Walk in box, one turn each way and walk out box
9. Side pass left
10. Walk over bridge to finish